

Site Inventory Form
State Historical Society of Iowa
 (December 1, 1999)

State Inventory No. 70-00968 **New** **Supplemental**
 Part of a district with known boundaries (enter inventory no.) _____
 Relationship: Contributing Noncontributing
 Contributes to a potential district with yet unknown boundaries
 National Register Status: (any that apply) Listed De-listed NHL DOE
 Review & Compliance No. _____
 Non-Extant (enter year) _____

1. Name of Property

historic name Commercial Building
 other names/site number HNI (HON) Headquarters, Field Site #: FS-121

2. Location

street & number 414 (412-418) E. Third Street
 city or town Muscatine vicinity, county Muscatine
 Legal Description: (If Rural) Township Name _____ Township No. _____ Range No. _____ Section _____ Quarter of Quarter _____
 (If Urban) Subdivision Original Town Block(s) 30 Lot(s) 6, 7, 8, 9

3. State/Federal Agency Certification [Skip this Section]

4. National Park Service Certification [Skip this Section]

5. Classification

Category of Property (Check only one box)	Number of Resources within Property	
	If Non-Eligible Property	If Eligible Property, enter number of:
<input checked="" type="checkbox"/> building(s)	Enter number of:	Contributing Noncontributing
<input type="checkbox"/> district	<u>1</u> buildings	_____ buildings
<input type="checkbox"/> site	_____ sites	_____ sites
<input type="checkbox"/> structure	_____ structures	_____ structures
<input type="checkbox"/> object	_____ objects	_____ objects
	<u>1</u> Total	_____ Total

Name of related project report or multiple property study (Enter "N/A" if the property is not part of a multiple property examination).
 Title _____ Historical Architectural Data Base Number _____

Historical and Architectural Survey and Evaluation of the Downtown Commercial District 70-013

6. Function or Use

Historic Functions (Enter categories from instructions)	Current Functions (Enter categories from instructions)
<u>02A07: Commercial/Business/Implement Dealer</u>	<u>02A01: Commercial/Office Building</u>
_____	_____
_____	_____

7. Description

Architectural Classification (Enter categories from instructions)	Materials (Enter categories from instructions)
_____	foundation <u>10B: Concrete/Poured</u>
_____	walls <u>03: Brick</u>
_____	roof <u>15C: Rubber</u>
_____	other _____

Narrative Description (SEE CONTINUATION SHEETS, WHICH MUST BE COMPLETED)

8. Statement of Significance

Applicable National Register Criteria (Mark "x" representing your opinion of eligibility after applying relevant National Register criteria)

<input type="checkbox"/> Yes <input checked="" type="checkbox"/> No <input type="checkbox"/> More Research Recommended	A	Property is associated with significant events.
<input type="checkbox"/> Yes <input checked="" type="checkbox"/> No <input type="checkbox"/> More Research Recommended	B	Property is associated with the lives of significant persons.
<input type="checkbox"/> Yes <input checked="" type="checkbox"/> No <input type="checkbox"/> More Research Recommended	C	Property has distinctive architectural characteristics.
<input type="checkbox"/> Yes <input type="checkbox"/> No <input type="checkbox"/> More Research Recommended	D	Property yields significant information in archaeology or history.

County Muscatine Address 414 E. 3rd Street Site Number 70-00968
City Muscatine District Number _____

Criteria Considerations

- A Owned by a religious institution or used for religious purposes.
- B Removed from its original location.
- C A birthplace or grave.
- D A cemetery.
- E A reconstructed building, object, or structure.
- F A commemorative property.
- G Less than 50 years of age or achieved significance within the past 50 years.

Areas of Significance (Enter categories from instructions)

Significant Dates

Construction date 1885 check if circa or estimated date
Other dates _____

Significant Person

(Complete if National Register Criterion B is marked above)

Architect/Builder

Architect _____

Builder _____

Narrative Statement of Significance SEE CONTINUATION SHEETS, WHICH MUST BE COMPLETED

9. Major Bibliographical References

Bibliography See continuation sheet for citations of the books, articles, and other sources used in preparing this form

10. Geographic Data

UTM References (OPTIONAL)

Zone	Easting	Northing	Zone	Easting	Northing
1	_____	_____	2	_____	_____
3	_____	_____	4	_____	_____

See continuation sheet for additional UTM references or comments

11. Form Prepared By

name/title Jim Rudisill, Planning & Community Development Coordinator (R.L. McCarley, Consultant)
organization Muscatine Historic Preservation Commission date May 12, 2005
street & number 215 Sycamore telephone 563-264-1554
city or town Muscatine state Iowa zip code 52761

ADDITIONAL DOCUMENTATION (Submit the following items with the completed form)

FOR ALL PROPERTIES

- Map:** showing the property's location in a town/city or township.
- Site plan:** showing position of buildings and structures on the site in relation to public road(s).
- Photographs:** representative black and white photos. If the photos are taken as part of a survey for which the Society is to be curator of the negatives or color slides, a photo/catalog sheet needs to be included with the negatives/slides and the following needs to be provided below on this particular inventory site:

Roll/slide sheet # _____ Frame/slot # _____ Date Taken _____
Roll/slide sheet # _____ Frame/slot # _____ Date Taken _____
Roll/slide sheet # _____ Frame/slot # _____ Date Taken _____

- See continuation sheet or attached **photo & slide catalog sheet** for list of photo roll or slide entries.
- Photos/illustrations without negatives are also in this site inventory file.

FOR CERTAIN KINDS OF PROPERTIES, INCLUDE THE FOLLOWING AS WELL

- Farmstead & District:** (List of structures and buildings, known or estimated year built, and contributing or non-contributing status)
- Barn:**
 - A sketch of the frame/truss configuration in the form of drawing a typical middle bent of the barn.
 - A photograph of the loft showing the frame configuration along one side.
 - A sketch floor plan of the interior space arrangements along with the barn's exterior dimensions in feet.

State Historic Preservation Office (SHPO) Use Only Below This Line

Concur with above survey opinion on National Register eligibility: Yes No More Research Recommended
 This is a locally designated property or part of a locally designated district.

Comments: _____

Evaluated by (name/title): _____ Date: _____

Iowa Site Inventory Form Continuation Sheet

Page 3

<u>Commercial Building</u>	<u>Muscatine</u>
Name of Property	County
<u>414 (412-418) East 3rd Street</u>	<u>Muscatine</u>
Address	City

7. Narrative Description

The present structure at 414 East 3rd Street is actually two c.1880 buildings that have been connected by a remodeled façade. In addition to this work, the 1970s remodeling has also connected these joined buildings to a c.1960 concrete block structure that appears to have been located around 420 E. 3rd Street. A new structure was also built to the west of the joined buildings at some time, creating an irregularly massed building that now houses the administrative offices of the HNI Corporation (formerly the HON Company).

The brick in both buildings are similar and has been laid in common bond. There is also an opening in their common wall in the attic, which according to the Sanborn maps, appears to have existed for several years. However, the floor joists in each building run perpendicular to each other and the attic floors are at slightly different levels, indicating the structures were constructed at different times.

The existing brick north façade includes a row of 10, tall, narrow, fixed windows in the second floor area. Each of these is estimated to be approximately 12' x 2'. Below the six east (left) windows in this row are three fixed windows that each measure around 24" x 60". Below these windows are three recessed, blind openings that each measure around 80" x 60". To the right of the smaller windows and the blind openings is the main entryway into the building. The entryway is recessed, with a double-unit glass door that is approximately 108" by 48". Two glass panels of the same size are located to the right of the entrance door. Other fenestration includes five windows (approximately 30" x 30") on the east elevation. A small addition on the west side of the building has nine recessed windows in its façade.

The façade renovation did not extend to the buildings' sides or back, although previous work did impact various original openings. The back of the building has been parged. Most of the original interior has been altered, except in the attic, where the original flooring, roof supports and similar detail can be seen.

8. Narrative Statement of Significance

The commercial building at 414 E. 3rd St was significantly remodeled in the 1970s after HON moved into the building. The original appearance has been completely obscured by the new brick façade and other alterations. Thus, it has lost the integrity to convey its significance as a historic building, and it is not individually eligible for the National Register of Historic Places. Additionally, this building is not a contributing structure in the potential downtown historic district

Based on an examination of the 1883 Sanborn map and city directories, both of the original buildings appear to have been constructed prior to 1883; and initial commercial activities in both appear to have been agriculturally related. Joseph and William Ament may have constructed the buildings, since both are shown as operating separate businesses from them in 1883. Joseph operated a carriage manufacturing business at what was then 412 E. 3rd Street, while William ran a farm implement operation at 418 E. 3rd. Carriages continued to be manufactured at the site until 1927, with the exception of a few years around

Iowa Site Inventory Form Continuation Sheet

Page 4

<u>Commercial Building</u> Name of Property	<u>Muscatine</u> County
<u>414 (412-418) East 3rd Street</u> Address	<u>Muscatine</u> City

the turn of the century when a button company operated from the building. The farm implement operation was replaced by blacksmith James O'Toole for several years during the early 1900s.

Eventually the buildings were converted into vehicle parts and repair businesses. HON purchased the site in 1973 and began renovating it for office space soon after that. In 2005, HNI (formerly HON) sold this building to Muscatine County for additional courthouse space, and began the renovation of their new headquarters in the former Baker Hospital No. 2 at 408 E. 2nd Street (Tecklenburg, May 2005).

9. Major Bibliographical References

City Directories, Muscatine. Various publishers, 1856-present. Available at the Musser Public Library.

Sanborn Map Company, New York. Maps of the City of Muscatine dated September 1883, August 1888, October 1892, August 1899, December 1905, February 1912, July 1919, March 1928 and June 1946.

Stelzner, Glenn, HNI Corporate Facilities Manager. Interview by Jim Rudisill, February 4, 2005, Muscatine, Iowa.

Tecklenburg, Jeff. "HNI announces HQ plans," *Muscatine Journal*, May 20, 2005.

Location Map

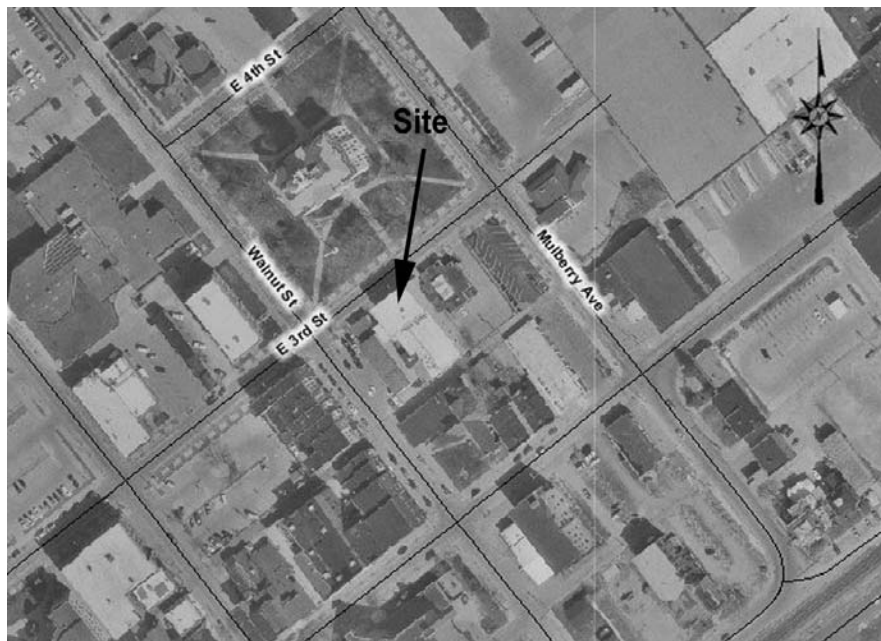

Iowa Site Inventory Form Continuation Sheet

Page 5

Commercial Building
Name of Property

Muscatine
County

414 (412-418) East 3rd Street
Address

Muscatine
City

Plan (from assessor's office)

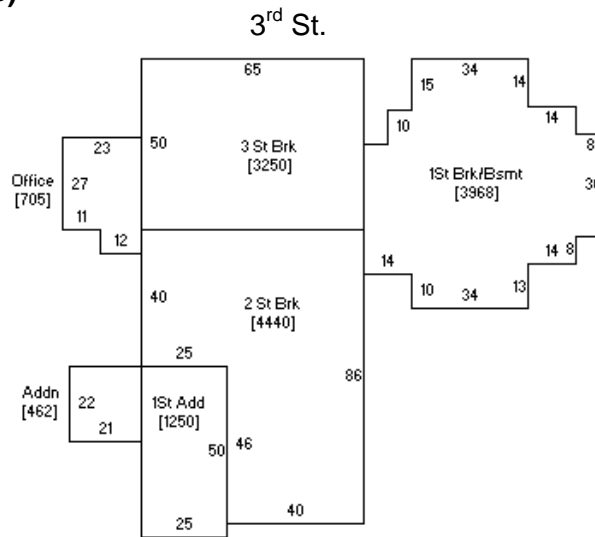

Photograph of building (digital image)

