

Site Inventory Form
State Historical Society of Iowa
 (December 1, 1999)

State Inventory No. 70-00234 New Supplemental
 Part of a district with known boundaries (enter inventory no.) 70-01005
 Relationship: Contributing Noncontributing
 Contributes to a potential district with yet unknown boundaries
 National Register Status: (any that apply) Listed De-listed NHL DOE
 Review & Compliance No. _____
 Non-Extant (enter year) _____

1. Name of Property

historic name Henry Waterman Moore House
 other names/site number Field Site #: WH-093

2. Location

street & number 716 West Third Street
 city or town Muscatine vicinity, county Muscatine
 Legal Description: (If Rural) Township Name _____ Township No. _____ Range No. _____ Section _____ Quarter of Quarter _____

 (If Urban) Subdivision Original Town Block(s) 40 Lot(s) 9 and 10

3. State/Federal Agency Certification [Skip this Section]

4. National Park Service Certification [Skip this Section]

5. Classification

Category of Property (Check only one box)	Number of Resources within Property	
	If Non-Eligible Property	If Eligible Property, enter number of:
<input checked="" type="checkbox"/> building(s)	Enter number of:	Contributing Noncontributing
<input type="checkbox"/> district	_____ buildings	<u>2</u> _____ buildings
<input type="checkbox"/> site	_____ sites	_____ sites
<input type="checkbox"/> structure	_____ structures	_____ structures
<input type="checkbox"/> object	_____ objects	_____ objects
	_____ Total	<u>2</u> _____ Total

Name of related project report or multiple property study (Enter "N/A" if the property is not part of a multiple property examination).
 Title _____ Historical Architectural Data Base Number _____

A Historical and Architectural Survey of the "West Hill" neighborhood, Muscatine, Iowa 70-016

6. Function or Use

Historic Functions (Enter categories from instructions)	Current Functions (Enter categories from instructions)
<u>01A01: Domestic / Single residence</u>	<u>01A01: Domestic / Single residence</u>
_____	_____
_____	_____

7. Description

Architectural Classification (Enter categories from instructions)	Materials (Enter categories from instructions)
<u>05B: Late Victorian / Italianate</u>	foundation <u>04C: Stone / Limestone</u>
_____	walls <u>02: Wood</u>
_____	roof <u>08A: Asphalt / Shingle</u>
_____	other _____

Narrative Description (SEE CONTINUATION SHEETS, WHICH MUST BE COMPLETED)

8. Statement of Significance

Applicable National Register Criteria (Mark "x" representing your opinion of eligibility after applying relevant National Register criteria)

<input checked="" type="checkbox"/> Yes <input type="checkbox"/> No <input type="checkbox"/> More Research Recommended	A	Property is associated with significant events.
<input checked="" type="checkbox"/> Yes <input type="checkbox"/> No <input type="checkbox"/> More Research Recommended	B	Property is associated with the lives of significant persons.
<input checked="" type="checkbox"/> Yes <input type="checkbox"/> No <input type="checkbox"/> More Research Recommended	C	Property has distinctive architectural characteristics.
<input type="checkbox"/> Yes <input type="checkbox"/> No <input type="checkbox"/> More Research Recommended	D	Property yields significant information in archaeology or history.

County Muscatine
City Muscatine

Address 716 West Third Street

Site Number 70-00234
District Number 70-01005

Criteria Considerations

- A Owned by a religious institution or used for religious purposes.
- B Removed from its original location.
- C A birthplace or grave.
- D A cemetery.
- E A reconstructed building, object, or structure.
- F A commemorative property.
- G Less than 50 years of age or achieved significance within the past 50 years.

Areas of Significance (Enter categories from instructions)

31: Other - neighborhood development

05: Commerce; 02: Architecture

Significant Dates

Construction date

1852 check if circa or estimated date

Other dates

Significant Person

(Complete if National Register Criterion B is marked above)

Henry Waterman Moore

Architect/Builder

Architect

Josiah Proctor Walton

Builder

Josiah Proctor Walton

Narrative Statement of Significance SEE CONTINUATION SHEETS, WHICH MUST BE COMPLETED

9. Major Bibliographical References

Bibliography See continuation sheet for citations of the books, articles, and other sources used in preparing this form

10. Geographic Data

UTM References (OPTIONAL)

Zone	Easting	Northing	Zone	Easting	Northing
1			2		
3			4		

See continuation sheet for additional UTM references or comments

11. Form Prepared By

name/title Maryrose and John Peterschmidt (Member and Volunteer) (R.L. McCarley, consultant)

organization Muscatine Historic Preservation Commission date November 22, 2005

street & number 215 Sycamore telephone 563-264-1550

city or town Muscatine state IA zip code 52761

ADDITIONAL DOCUMENTATION (Submit the following items with the completed form)

FOR ALL PROPERTIES

- Map:** showing the property's location in a town/city or township.
- Site plan:** showing position of buildings and structures on the site in relation to public road(s).
- Photographs:** representative black and white photos. If the photos are taken as part of a survey for which the Society is to be curator of the negatives or color slides, a photo/catalog sheet needs to be included with the negatives/slides and the following needs to be provided below on this particular inventory site:

Roll/slide sheet # _____ Frame/slot # _____ Date Taken _____
Roll/slide sheet # _____ Frame/slot # _____ Date Taken _____
Roll/slide sheet # _____ Frame/slot # _____ Date Taken _____

- See continuation sheet or attached **photo & slide catalog sheet** for list of photo roll or slide entries.
- Photos/illustrations without negatives are also in this site inventory file.

FOR CERTAIN KINDS OF PROPERTIES, INCLUDE THE FOLLOWING AS WELL

- Farmstead & District:** (List of structures and buildings, known or estimated year built, and contributing or non-contributing status)
- Barn:**
 - A sketch of the frame/truss configuration in the form of drawing a typical middle bent of the barn.
 - A photograph of the loft showing the frame configuration along one side.
 - A sketch floor plan of the interior space arrangements along with the barn's exterior dimensions in feet.

State Historic Preservation Office (SHPO) Use Only Below This Line

Concur with above survey opinion on National Register eligibility: Yes No More Research Recommended
 This is a locally designated property or part of a locally designated district.

Comments: _____

Evaluated by (name/title): _____ Date: _____

Iowa Site Inventory Form Continuation Sheet

Page 3

Henry Waterman Moore House
Name of Property

Muscatine
County

716 West Third Street
Address

Muscatine
City

7. Narrative Description

This is a two-story, three-bay, Italianate house. The house sits on a brick foundation. The walls are clad in wood clapboard. The hipped roof is clad in asphalt shingles. It retains several features characteristic of the Italianate style, including the overall form and composition, full front porch, brackets, wide eaves, and large belvedere. A photograph that appears in a c.1914 publication shows that this building has changed little in ninety years (*Muscatine, Iowa The Pearl City* 1914: 81).

The front (north) elevation reveals the building to be three bays wide with a full width porch and a centered entry. The single door entry is flanked by narrow sidelights, with a three pane transom. Six-over-six-light, double-hung windows, with lintels that are topped with a crown molding are to the left and right of the entry. Likewise, three such windows can be found on the second story. All of these windows have a pair of shutters attached. A front porch extends across the elevation. The porch posts have a base that is raised several feet above the porch floor. The porch floor is two steps above grade. There is no railing between posts. The posts are square with chamfered corners, rising to a capital that is also square and a bit larger. Above each post is seen a decorative bracket beneath the porch roof, as well as short lengths of decorative, flat, scrollwork under the porch frieze. Dentils are continuous between the post brackets on the porch frieze. A balustrade on the porch roof reveals decorative, turned spindles with support posts that mimic the design seen in the porch posts below. Paired brackets are seen at the roof eave, along with dentil molding, between bays and at the corners of the front elevation.

Atop the truncated hipped roof of this building is a large belvedere. It is surrounded by a balustrade that is identical in design to the one found on the front porch. The north and south elevation of the belvedere show three narrow arch windows. The center window is a four-over-four-light double-hung window and the other two windows are two-over-two-light double-hung windows. The east and west elevations show two paired, four-over-four-light double-hung windows. At the eave of the belvedere are paired brackets, identical in design, but smaller in size to those found on the main building. Rising above the roof of the belvedere are four identical brick chimneys.

The east elevation of the main building is two large bays wide. The windows found on this elevation are identical to those found on the front, or north, elevation. Paired brackets between bays, with dentil molding between them can also be found on this elevation. To the left of the main building on this elevation, is seen a one-and-one-half-story wing projecting south, that is two bays wide. In front of, and projecting a few feet from the main building, is an enclosed, three season porch with a single entry adjacent to the main building and another on the south elevation. Design elements such as the eave dentil molding and brackets, identical to the main building, appear on this porch. This porch is not seen on Sanborn maps from 1905 through 1946.

The west elevation of the main building is identical to the east elevation in regard to size, window description and placement, and eave description, except that a bay window is located on the first story on the right. In it there are 4 four-over-four-light, double-hung windows with shutters. The lintels found above these windows are topped with crown molding, then a frieze made up of brackets, dentil molding

Iowa Site Inventory Form Continuation Sheet

Page 4

Henry Waterman Moore House
Name of Property

Muscatine
County

716 West Third Street
Address

Muscatine
City

and decorative, flat scrollwork similar to that found on the front porch. Above the bay window roof is found a balustrade with turned, decorative spindles, identical to those found above the front porch and surrounding the belvedere. To the right of the main building on this elevation is seen the one and a half story wing. A single entry is found at the left, near the main building. It is accessed from a recently built vinyl-clad deck that is the same length as the south wing. Historically, a porch was found along this elevation of the south wing (Sanborn maps, 1905, 1912 and 1919). It was likely enclosed during the 1920's and appears as a one-story part of the building in the Sanborn map of 1928.

The rear, or south elevation of 716 West Third Street shows the south wing to have a single, small, double-hung window on the first story and a six-over-six-light, double-hung window on the upper story. A tall painted brick chimney projects above the south wing. A hipped roof dormer is seen on the roof of the main building. It has a four-over-four-light, double-hung window with half round lintel.

At the rear of the property is found a three-story carriage house that functions today as a two car garage with storage space above. It is a gable-roof building with a ridge that is parallel to Third Street and a brick chimney at each gable end. It is two bays wide and two bays long with unadorned six-over-six-light, double-hung windows on the upper stories of the south elevation and one six-over-six-light, double-hung window on the west elevation as well as two paired, two-over-two-light, double-hung windows. There is a one-story brick shed attached to this building to the east that functions as additional garage space. Historically, there were two livery stables at the rear of this property. The other livery was at the southeast corner of the property and was removed in the 1920's, according to Sanborn maps.

Connecting the south wing with the brick garage is a brick walled, arched tunnel that has a gabled structure above it. The roof of this tunnel provides the walkway to the upper stories of the garage. Originally, it was designed to provide all weather access to a privy, which was in the brick building. ("Historic Homes" Clipping file, Musser Public Library). The structure has lattice-like walls and a standing seam metal roof.

The property is surrounded by an original wrought iron fence with two gates.

8. Narrative Statement of Significance

The Henry Waterman Moore House appears to be individually eligible for the National Register of Historic Places under Criterion B and C. Also, it appears to be a contributing building in a potential "West Hill" neighborhood historic district.

The history of this property is centered on a Muscatine pioneer, financier and developer, Henry Waterman Moore. He was a leader in Muscatine's early commercial development years, beginning his career in the early 1850s. His business endeavors were successful and continued through the 19th century. "He became connected with many of our public improvements, such as water works, railroads, banks; and served on the school board; also in the honorable office of alderman; in fact, movements of

Iowa Site Inventory Form Continuation Sheet

Page 5

Henry Waterman Moore House
Name of Property

Muscatine
County

716 West Third Street
Address

Muscatine
City

public interest could rarely be found where Mr. Moore was not a prominent man” (Walton 1899: 56). Thus, the Henry Waterman Moore House appears to be individually eligible under Criterion B. The Italianate architecture is one of the largest and most formally developed examples of Italianate architecture in Muscatine. It retains several features characteristic of the style, including the cubical form, large brackets, entry with sidelights and transom, porch with decorative woodwork, and cupola. As a early example of Italianate in Muscatine, built c.1852, it reflects some carryover of earlier features, such as the six-over-six-light double-hung windows and dentils. Also, the architect and builder of the Henry Waterman Moore House, Josiah Proctor Walton, was a significant Muscatine pioneer in his own right. An article published in *The Iowan* magazine states “The design of the Randall and Moore homes reflects the restraint of good taste that Walton brought to nineteenth century architecture in Muscatine, for they seem to incorporate all of the classic grace and none of the monstrosity typical of the period” (“Walton Homes”, *The Iowan*, Spring 1963: 48) His sensitive, elegant design is still to be admired as the architectural integrity is intact. Thus, the Henry Waterman Moore House appears to be individually eligible under Criterion C.

The Henry Waterman Moore House also appears to be a contributing building in a potential “West Hill” neighborhood historic district. One need not be an architect or historian to appreciate the classic beauty of this fine building, with its Italianate design. It fits well into its immediate surroundings, which include houses that are Greek Revival, Queen Anne and Craftsman in style. It reflects the earliest history of the district, during a period that substantial homes were constructed near the peak of 3rd Street. It represents one of the largest, most refined homes constructed in this period, which significantly contributed to the development of the neighborhood throughout the remainder of the 19th century and into the 20th century.

Henry Moore was a business owner, developer, and financier of enterprises in Muscatine. Henry Waterman Moore was born in Gardiner, Kennebec County, Maine on October 12, 1818. The history of his family in America dates to 1639, when his ancestors emigrated to the colony of Massachusetts. In 1838, he set out for the Mississippi River area, where his brother, Ebenezer, was mayor of Quincy, Illinois. He moved on upriver to Burlington, Iowa, which was, at that time, a part of the Territory of Wisconsin (Obit. In *Old Settlers Register*, page 400). In 1845, he moved upriver to Wapello, Iowa for a time before moving to Muscatine in 1848. He began his hardware business, at age 30, shortly after he moved to Muscatine. By 1852 he had repaid money loaned to him by a friend, Lyman Cook of the First National Bank of Burlington, Iowa, to start his business. In 1852, he became a promoter in the building of the Trinity Episcopal Church, and he and Ellen Stone became the first couple married here in 1853. She was the sister of Charles Stone, who was a developer, along with Henry, of business properties in the downtown (Richman 1911, Vol 2: 5-9).

It is recorded that Henry W. Moore bought lot 10 of block 40 from Abraham Smalley on October 8, 1850 and lot 9 of block 40 from Suel Foster on September 5, 1851. It is unlikely that construction began on the house before the spring of 1852. Mr. Moore engaged Josiah Proctor Walton to design and build his house (“Walton Homes”, *The Iowan*, 1963). The city directory of 1859-1860 indicates that his store was on the north side of Second Street on that date. Also, in that city directory, his home was listed at the

Iowa Site Inventory Form Continuation Sheet

Page 6

Henry Waterman Moore House
Name of Property

Muscatine
County

716 West Third Street
Address

Muscatine
City

south side of 3rd St. between Cherry and Broadway, which indicates that he was prosperous and stable in his hardware business venture. A print by Augustus Koch in 1874 clearly shows the Moore property at the corner of Third and Cherry Streets (Koch 1874).

Ellen Stone Moore died on February 5, 1859, leaving two sons: Henry Stone Moore, born December 21, 1855, and George, born January 27, 1859. (*Portrait and Biographical Album* 1889: 380) The 1860 census lists Henry Sr. as a 49-year-old iron merchant, born in Maine. Also, his household at this time consisted of his sisters Martha, age 45, and Mary Southgate, age 43; sons Henry Stone, age 4 and George, age 1. A servant, Catherine Hearty, from Ireland is also listed. The 1880 Census lists Henry W. Moore as a 61 year old hardware merchant. In his household lived sons Henry S. and George, sisters Martha and Mary. Martha died on September 2, 1893. City directory listings from 1860 to 1894 show the H.W. Moore Hardware Store at 218-220 East 2nd Street and his residence as 716 West 3rd Street. Henry Waterman Moore died while at his hardware store on East Second Street on February 26, 1894 (Obit. Old Settlers Register, 400).

Richman wrote in 1911 about Moore: "The names of some are indelibly written upon the pages of Muscatine's history, but none shine with brighter lustre than that of Henry Waterman Moore, who in every relation of life measured up to the highest standards of manhood and citizenship." In addition to being a successful businessman, he was president of the Muscatine Insurance Company from 1852 to 1860; became an organizer of the Merchants Exchange Bank in 1866 and was a member of the board of directors and vice president; treasurer of the Iowa Construction Company, which built the Muscatine Western Railway in 1873-1874; stockholder and treasurer of the Muscatine Waterworks Company in 1875; stockholder and director of the Hershey Lumber Company in 1875; organizer of the Muscatine Oat Meal Company in 1879; organizer and director of the Muscatine Island Canning Company and, in 1892, he was an organizer of Muscatine Pearl Button Company. Following its organization in 1880, Henry was president of the Muscatine Savings Bank and from 1892 to 1894, he was president of the First National Bank, as well. Henry served in a civic capacity, also. He was elected to the city council in 1865 for a two year term and appointed to the school board in 1864, also for two years (Richman 1911, Vol 2: 5-9).

After the death of Henry W. Moore in 1894, this property was passed on to his son Henry Stone Moore. Henry S. Moore continued to live at 716 West 3rd Street and was married to Genes Johnson on October 7, 1897. The city directories agree with this information. City directories also refer to Mr. Moore's occupation as a capitalist. The 1900 Census shows that Henry S. Moore, age 44 and his wife, Genes, age 28, lived at 716 West 3rd Street with their son Henry W. Moore, who was one year old at the time. City directories continue to list Henry S. Moore and his family at this address. The 1910 Census indicated that the family had grown. Frank R. Moore was born in 1902 and Maurice W. Moore was born in 1907. Henry Stone Moore died on December 30, 1918 at 63 years of age. The 1920 Census shows only Mrs. Moore and her three sons Henry (21), Frank (17), and Maurice (13). Mrs. Genes Moore continued to live here until 1943. These events are verified by the city directories, which only list Mrs. Moore at 716 West 3rd Street for the period 1921 through 1943.

Iowa Site Inventory Form Continuation Sheet

Site Number 70-00234

Related District Number 70-01005

Page 7

Henry Waterman Moore House
Name of Property

Muscatine
County

716 West Third Street
Address

Muscatine
City

Mrs. Genes Moore continued to live here until she sold the property to Gilbert G. and Lena M. Oberhaus on March 24, 1943. Genes Johnson Moore died on April 16, 1944. Mr. Oberhaus was a sign painter by trade. City directories show that the Oberhaus family lived here from 1943 to 1961. On May 16, 1961, the property was sold to Dr. Dale Longtin, D.V.M. and his wife, Midge.

9. Major Bibliographical References

Andreas, A.T. *Illustrated Historical Atlas of the State of Iowa*. Chicago, 1875.

City Directories, Muscatine. Various publishers, 1856-1959. Available as the Musser Public Library.

Clippings Files, Musser Public Library, Muscatine, Iowa.

Deed/Abstract Records, Recorder's Office, Muscatine County Courthouse, Muscatine, Iowa.

History of Muscatine County, Iowa. Chicago: Western Historical Company, 1879.

Iowa Cemetery Records, available online at www.ancestry.com

Iowa Marriages, available online at www.ancestry.com

Koch, Augustus. Bird's-eye View of the City of Muscatine, Muscatine County, Iowa. Koch, 1874. In the collections of the State Historical Society of Iowa, Iowa City, Iowa.

Muscatine, Iowa: The Pearl City. Record Printing Co., 1914

Old Settlers Register. A Collection of obituaries, accounts of reunions and history articles; Bound and Presented to the Old Settlers Society by S.C. Dunn, 1875. Available at the Musser Public Library

Portrait and Biographical Album of Muscatine County, Iowa. Chicago: Acme Publishing, 1889.

Richman, Irving B. *History of Muscatine County, Iowa*. Chicago: S.J. Clarke Publishing Company, 1911.

Sanborn Map Company. "Muscatine, Iowa," Sanborn fire insurance maps. Pelham, NY: Sanborn Map Company, 1883, 1888, 1892, 1899, 1907, 1912, 1919, 1928. Accessed online at: Sanborn.umi.com.

"Walton Homes", *The Iowan*. Vol. II, No. 3, Spring, 1963. page 48. Mid-America Publishing Corporation, Des Moines, Iowa. In Clippings Files – Historic Homes, Musser Public Library, Muscatine.

Iowa Department of Cultural Affairs
State Historical Society of Iowa
Iowa Site Inventory Form
Continuation Sheet

Site Number 70-00234
Related District Number 70-01005

Page 8

Henry Waterman Moore House
Name of Property

Muscatine
County

716 West Third Street
Address

Muscatine
City

Walton, Josiah. Pioneer papers, comprising a collection of the recollections of early events of Bloomington, Iowa, now Muscatine, and its surroundings. 1899

Location Map



Iowa Site Inventory Form Continuation Sheet

Site Number 70-00234

Related District Number 70-01005

Page 9

Henry Waterman Moore House
Name of Property

Muscatine
County

716 West Third Street
Address

Muscatine
City

Plans of buildings on site (from assessor's office)

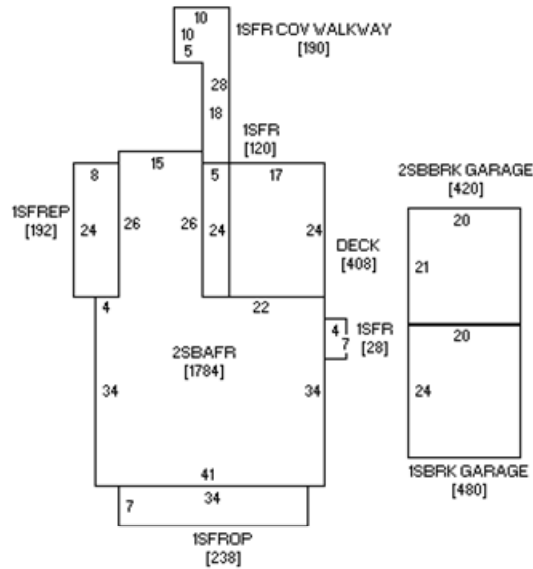

(front – 3rd Street)

Photograph of building (digital images)



**Iowa Site Inventory Form
Continuation Sheet**

Site Number 70-00234

Related District Number 70-01005

Page 10

Henry Waterman Moore House
Name of Property

Muscatine
County

716 West Third Street
Address

Muscatine
City

