

**Site Inventory Form**  
**State Historical Society of Iowa**  
 (December 1, 1999)

State Inventory No. 70-01116       **New**    **Supplemental**  
 Part of a district with known boundaries (enter inventory no.) 70-01005  
 Relationship:    Contributing    Noncontributing  
 Contributes to a potential district with yet unknown boundaries  
 National Register Status: (any that apply)    Listed    De-listed    NHL    DOE  
 Review & Compliance No. \_\_\_\_\_  
 Non-Extant (enter year) \_\_\_\_\_

**1. Name of Property**

historic name Smith-Sweet House  
 other names/site number Field Site #: WH-123

**2. Location**

street & number 406 Chestnut  
 city or town Muscatine       vicinity, county Muscatine  
 Legal Description: (If Rural) Township Name \_\_\_\_\_ Township No. \_\_\_\_\_ Range No. \_\_\_\_\_ Section \_\_\_\_\_ Quarter of Quarter \_\_\_\_\_  
 \_\_\_\_\_  
 \_\_\_\_\_  
 (If Urban) Subdivision Original Town      Block(s) 79 Lot(s) S 40' 4" N 79'8-3/4F" Lot 5

**3. State/Federal Agency Certification [Skip this Section]**

**4. National Park Service Certification [Skip this Section]**

**5. Classification**

Category of Property (Check only one box)	Number of Resources within Property		
	If Non-Eligible Property	If Eligible Property, enter number of:	
<input checked="" type="checkbox"/> building(s)	Enter number of:	Contributing	Noncontributing
<input type="checkbox"/> district	_____ buildings	<u>2</u>	_____ buildings
<input type="checkbox"/> site	_____ sites	_____	_____ sites
<input type="checkbox"/> structure	_____ structures	_____	_____ structures
<input type="checkbox"/> object	_____ objects	_____	_____ objects
	_____ Total	<u>2</u>	_____ Total

Name of related project report or multiple property study (Enter "N/A" if the property is not part of a multiple property examination).  
 Title \_\_\_\_\_ Historical Architectural Data Base Number \_\_\_\_\_

A Historical and Architectural Survey of the "West Hill" neighborhood, Muscatine, Iowa      70-016

**6. Function or Use**

Historic Functions (Enter categories from instructions)	Current Functions (Enter categories from instructions)
<u>01A01: Domestic / Single residence</u>	<u>01A01: Domestic/Single residence</u>
_____	_____
_____	_____

**7. Description**

Architectural Classification (Enter categories from instructions)	Materials (Enter categories from instructions)
<u>09A01: House / Front-Gabled Roof</u>	foundation <u>10A: Concrete/Block</u>
_____	walls <u>05F: Metal/Steel</u>
_____	roof <u>08A: Asphalt/Shingle</u>
_____	other _____

**Narrative Description** ( SEE CONTINUATION SHEETS, WHICH MUST BE COMPLETED)

**8. Statement of Significance**

Applicable National Register Criteria (Mark "x" representing your opinion of eligibility after applying relevant National Register criteria)	
<input checked="" type="checkbox"/> Yes <input type="checkbox"/> No <input type="checkbox"/> More Research Recommended	A Property is associated with significant events.
<input type="checkbox"/> Yes <input checked="" type="checkbox"/> No <input type="checkbox"/> More Research Recommended	B Property is associated with the lives of significant persons.
<input checked="" type="checkbox"/> Yes <input type="checkbox"/> No <input type="checkbox"/> More Research Recommended	C Property has distinctive architectural characteristics.
<input type="checkbox"/> Yes <input type="checkbox"/> No <input type="checkbox"/> More Research Recommended	D Property yields significant information in archaeology or history.

County Muscatine  
City Muscatine

Address 406 Chestnut

Site Number 70-01116  
District Number 70-01005

**Criteria Considerations**

- A Owned by a religious institution or used for religious purposes.
- B Removed from its original location.
- C A birthplace or grave.
- D A cemetery.
- E A reconstructed building, object, or structure.
- F A commemorative property.
- G Less than 50 years of age or achieved significance within the past 50 years.

**Areas of Significance** (Enter categories from instructions)

31: Other/Neighborhood development

02: Architecture

**Significant Dates**

Construction date

1898

check if circa or estimated date

Other dates

**Significant Person**

(Complete if National Register Criterion B is marked above)

\_\_\_\_\_  
\_\_\_\_\_

**Architect/Builder**

Architect

\_\_\_\_\_  
Builder

**Narrative Statement of Significance**  SEE CONTINUATION SHEETS, WHICH MUST BE COMPLETED

**9. Major Bibliographical References**

Bibliography  See continuation sheet for citations of the books, articles, and other sources used in preparing this form

**10. Geographic Data**

**UTM References (OPTIONAL)**

Zone	Easting	Northing	Zone	Easting	Northing
1	_____	_____	2	_____	_____
3	_____	_____	4	_____	_____

See continuation sheet for additional UTM references or comments

**11. Form Prepared By**

name/title Jim Rudisill, Planning & CD Coordinator

organization Muscatine Historic Preservation Commission date November 14, 2005

street & number 215 Sycamore telephone 563-264-1550

city or town Muscatine state IA zip code 52761

**ADDITIONAL DOCUMENTATION (Submit the following items with the completed form)**

**FOR ALL PROPERTIES**

- Map:** showing the property's location in a town/city or township.
- Site plan:** showing position of buildings and structures on the site in relation to public road(s).
- Photographs:** representative black and white photos. If the photos are taken as part of a survey for which the Society is to be curator of the negatives or color slides, a photo/catalog sheet needs to be included with the negatives/slides and the following needs to be provided below on this particular inventory site:

Roll/slide sheet # \_\_\_\_\_ Frame/slot # \_\_\_\_\_ Date Taken \_\_\_\_\_  
Roll/slide sheet # \_\_\_\_\_ Frame/slot # \_\_\_\_\_ Date Taken \_\_\_\_\_  
Roll/slide sheet # \_\_\_\_\_ Frame/slot # \_\_\_\_\_ Date Taken \_\_\_\_\_

- See continuation sheet or attached **photo & slide catalog sheet** for list of photo roll or slide entries.
- Photos/illustrations without negatives are also in this site inventory file.

**FOR CERTAIN KINDS OF PROPERTIES, INCLUDE THE FOLLOWING AS WELL**

- Farmstead & District:** (List of structures and buildings, known or estimated year built, and contributing or non-contributing status)
- Barn:**
  - A sketch of the frame/truss configuration in the form of drawing a typical middle bent of the barn.
  - A photograph of the loft showing the frame configuration along one side.
  - A sketch floor plan of the interior space arrangements along with the barn's exterior dimensions in feet.

**State Historic Preservation Office (SHPO) Use Only Below This Line**

Concur with above survey opinion on National Register eligibility:  Yes  No  More Research Recommended  
 This is a locally designated property or part of a locally designated district.

Comments: \_\_\_\_\_

Evaluated by (name/title): \_\_\_\_\_ Date: \_\_\_\_\_

# Iowa Site Inventory Form Continuation Sheet

Page 3

Smith-Sweet House  
Name of Property

Muscatine  
County

406 Chestnut  
Address

Muscatine  
City

## 7. Narrative Description

This is a two-story, two-bay, gable-front house with a two-story, angled bay window on the south side. The house sits on a beveled concrete block foundation, perhaps replacing an earlier foundation. The walls are frame, clad in original wood siding. The gable main roof is clad in asphalt shingles. A front and rear porch each has a hip roof that is also clad in asphalt shingles. Simple wood trim, including lintels, surround all the windows. No other decorative details are present. A set of steps and a small deck provides access to the front entry. This house is similar in design and shape to the adjoining property to the north (408 Chestnut). Based on reports from the current owners, Sanborn maps and property abstracts, it is believed that this house with built and historically remodeled at the same time as the adjacent 408 Chestnut. This house retains more historic features than the other house however, including historic wood windows

The steps and small deck on the front (east) elevation are non-historic and provides access to the main entry in the extended front gable. The entry is covered with a small gable roof supported by two brackets at each end. The entry includes a one-over-one-light, non-historic aluminum storm door and an interior entry door of unknown age. In addition to the front entry deck, the other façade openings include a large single-light fixed window with transom to the left of the entry door on the first story. Two one-over-one-light, double-hung windows are equally spaced on the second story. An attic vent opening is located in the middle of the upper gable. An enclosed porch extends out from the façade, around the house's southeast corner and continues along the south elevation to the bay window. This porch appears on the Sanborn maps, along with one at 408, between 1919 and 1928. The east elevation of the porch contains four, one-over-one-light, double-hung windows. Three of the windows face east, while the fourth window faces north towards the front deck.

The enclosed porch's south side elevation contains six one-over-one, double-hung windows in a single row. The first story of the angled bay window contains a one-over-one-light, double-hung window in the center of the wall. A similar window is located above it on the second story. Each of the outside bays of both stories contains similar windows. Decorative vergeboard extends across the cutaway section of the bay window on the second story. Two one-over-one-light, double-hung windows are located towards the front on the eave side of the front gable section.

The north elevation contains a side entry with a gable roof covering similar to the front entry. To the left of this entry is a small pair of single-light windows, while a typical one-over-one-light, double-hung window is located to the right of the side entry. The only second-story openings are a pair of typical one-over-one-light, double-hung windows that are located towards the back wall.

The main feature of the rear elevation is an enclosed, one-story porch that does not quite extend across the width of the back gable end. The porch contains two, one-over-one-light, double-hung window openings on its north wall. The west wall contains a back entry door with a one-over-one-light, double-hung window on each side of the door. It is unknown if there are any openings on the porch's south wall.

# Iowa Site Inventory Form Continuation Sheet

Page 4

---

<u>Smith-Sweet House</u>	<u>Muscatine</u>
Name of Property	County
<u>406 Chestnut</u>	<u>Muscatine</u>
Address	City

---

The remaining opening on the rear elevation is a single, one-over-one-light, double-hung window that is located in the middle of the second story. There is also an attic vent located in the upper gable.

## 8. Narrative Statement of Significance

The Smith-Sweet House does not appear to be individually eligible for the National Register of Historic Places under Criteria A, B, or C. However, it does appear to be a contributing building in a potential "West Hill" neighborhood historic district.

Chockley C. Smith acquired all of Lot 5, Block 79 from Porter Yates and Ella Forbes on September 20, 1898, subsequently building three houses. He rented this property at 406 Chestnut until after he approached retirement. Brayton Sweet was a railroad mail clerk, who appears to have moved to Muscatine from Davenport sometime around 1924, after he and his wife Elsie purchased 406 Chestnut from C.C. Smith. Although Smith constructed this house and several others on Lot 5, Block 79, Sweet's name is attached to the property because his residency is one of the longest associations with the property. There is no record of Sweet making any significant contribution to the community. Although the house does retain much of its integrity, with original wood siding, windows and some decorative vergeboard, those features are not particularly significant or unique. There is also no record of any significant historic event occurring on this property. Thus the C.C. Smith House does not appear to be individually eligible for the National Register of Historic Places under Criteria A, B, or C.

However, the Smith-Sweet House does appear to be a contributing building in a potential "West Hill" neighborhood historic district. All four houses currently located on Lot 5, Block 79 appear to have been constructed between 1898 and 1915 by Chockley C. Smith, a local businessman. This construction is a strong example of 19<sup>th</sup> and 20<sup>th</sup> Century Neighborhood Development, during a period that saw increased demand for housing. Smith helped strengthen the neighborhood by allowing new residents to move in and establish strong roots in the area. Although Sweet was not well known in the community in 1924, he did represent a new resident to the community. His decision to locate at 406 Chestnut was a sign that new families were moving into the community and boosting its diversity and number. The house also retains a significant amount of integrity. The house contributes both historically and architecturally to this potential historic district.

Local businessman Chockley C. Smith acquired all of Lot 5, Block 79 from Porter Yates and Ella Forbes on September 20, 1898 (Book 32, Page 339). It appears Yates and Forbes and other family members had acquired the property through a family transaction. Originally, Joseph Yates and L.D. Forbes purchased the property from Shep Smalley, a widower, on October 29, 1891 (Book 24, Page 53). None of the Forbes or Yates involved in these acquisitions appear in the 1870 or later census records, and their relationships are unknown.

Census records and city directories show Smith was living at 213 W Sixth Street at the time he bought the property. He is also listed at 213 W. Sixth Street in the 1900 Census, which notes that he is 35 years

# Iowa Site Inventory Form Continuation Sheet

Page 5

---

Smith-Sweet House  
Name of Property

Muscatine  
County

406 Chestnut  
Address

Muscatine  
City

---

old. He operated a grocery and later ran a button factory. After buying Lot 5, Block 79 in 1898, Smith immediately constructed three houses. He built a fourth house, initially as an addition, at 402 Chestnut around 1915.

The houses at 406 and 408 Chestnut appear identical on the 1899 and future maps. Their on-site appearance also appears similar to each other. Some details of the houses were simplified on the 1928 Sanborn map. The 1928 Sanborn map had several revisions along Chestnut Street that suggests map corrections in comparison to 1919 rather than new construction. The angled two-story bay window on the south side of the houses is shown in 1899 to 1919, and they are simplified and not shown as angled on the 1928 Sanborn map. However, the angled bay windows obviously continues to exist, and the houses overall appears to date to the earlier time frame.

The first family to be recorded as residents of 406 Chestnut was C.F. and Laura Gray, who are listed in the 1899-1900 and 1900 city directories. Gray was a bookkeeper for Van Nostrand Saddlery Company. William and Ada Mason were recorded in the 1904 directory as the residents. He was a draughtsman. The 1908-09 directory listed Arthur and Ellen Brandt as the residents. Brand was a real estate agent. Ruthven and Olive Leverich lived at 406 Chestnut from 1908 to around 1913, city directories show. He was the proprietor of the Leverich Normal School. The 1913 through the 1919 city directories identified Moses DeMarce and his wife Ina May as the residents. The DeMarces moved around 1921 into 402 Chestnut after buying that property from Chockley Smith, who moved into 406 Chestnut. Smith and his wife Adeline continued to live in the house into 1924, according to the city directories.

Between 1920 and 1924 Smith sold three of the properties he had developed, including 406 Chestnut, which was sold on July 21, 1924 (Lots Book 63, Page 241) to Brayton Sweet, a railway mail clerk from Davenport. The lot had been survey and split in 1920 for the sale. Each property was then identified by the survey description. The house at 201 W. Fourth received a legal description of the S 36'9-1/2" of Lot 5, Block 79. 408 Chestnut was legally described as the N 39'4-3/4" of Lot 5, Block 79. The third house was 406 Chestnut and was described as the S 40'4" N 79'8-3/4" of Lot 5, Block 79. The house at 402 Chestnut, built as an addition to 201 W. Fourth, was legally described as the N 23'5-3/4" of the S 60'3" of Lot 5, Block 79. These legal descriptions are actually simplified versions of more detailed survey descriptions that are included on the deeds. After Sweet bought the property in 1924, Sweet and his wife Elsie are listed as the residents of 406 Chestnut from the 1927 through the 1938-39 directories. Sweet is recorded in several census reports as a railway mail clerk and lived in Webster, Iowa and Davenport before settling in Muscatine. Muscatine city directories from 1927 through 1938-39 record his occupation variously as mail clerk, clerk or simply RyMS, which is assumed to be a railway line.

The Sweets sold the house to Gladys Phillips on February 16, 1940 (Book 89 Lots, Page 574). Phillips, whose occupation is unknown, apparently did not live in the house and about two months later, on June 24, 1940, sold the property to Mary Prosser. Prosser, a stenographer for Matthew Westrate, was listed as the resident in the 1943 and 1946 city directories. In addition to Prosser, Mrs. Ella Borgstandt, the widow of Louis, also was listed as a resident in the 1943 directory.

# Iowa Site Inventory Form Continuation Sheet

Page 6

Smith-Sweet House  
Name of Property

Muscatine  
County

406 Chestnut  
Address

Muscatine  
City

Prosser sold the property to Howard and Rose Hill on April 16, 1948 (Book 124 Lots, Page 506). Hill and his wife, who operated the Red Paint Store, are listed as residents of 406 Chestnut in the 1949 directory. They are also listed in the 1952 directory, along with Earl and Doris LaRoe. LaRoe worked at Grain Processing.

The property was sold by the Hills to Edward Dankert on June 1, 1954 (Book 148, Page 542). City directories from 1954 to 1961 list Mrs. Pearl Dankert, widow of Edward, as the resident, indicating Edward Dankert passed away shortly after purchasing the property. No occupation was recorded for Dankert. In addition to Dankert, Geneva N. Grace, a teacher at the Muscatine High School, is also listed as a resident in the 1954 through 1958 city directories. Dankert's heirs sold the property to Kevin and RayEllen Phillips on September 4, 1984 (Book 308, Page 238).

## 9. Major Bibliographical References

Census Records, United States Census Bureau, 1900, 1910, 1920.

City Directories, Muscatine. Various publishers, 1856-1959. Available as the Musser Public Library.

Deed/Abstract Records, Recorder's Office, Muscatine County Courthouse, Muscatine, Iowa.

Sanborn Map Company. "Muscatine, Iowa," Sanborn fire insurance maps. Pelham, NY: Sanborn Map Company, 1883, 1888, 1892, 1899, 1907, 1912, 1919, 1928. Accessed online at: [Sanborn.umi.com](http://Sanborn.umi.com).

## Location Map



# Iowa Site Inventory Form Continuation Sheet

Page 7

Smith-Sweet House  
Name of Property

Muscatine  
County

406 Chestnut  
Address

Muscatine  
City

## Plans of buildings on site (from assessor's office)

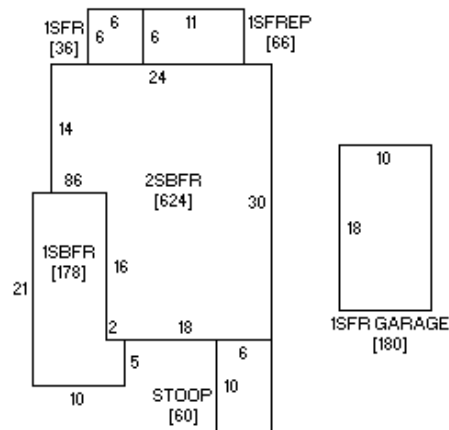

(front - 4<sup>th</sup> Street)

## Photograph of building (digital image)

