

Site Inventory Form
State Historical Society of Iowa
 (December 1, 1999)

State Inventory No. 70-01096 **New** **Supplemental**
 Part of a district with known boundaries (enter inventory no.) 70-01005
 Relationship: Contributing Noncontributing
 Contributes to a potential district with yet unknown boundaries
 National Register Status: (any that apply) Listed De-listed NHL DOE
 Review & Compliance No. _____
 Non-Extant (enter year) _____

1. Name of Property

historic name Hatch-Chaplin House
 other names/site number Field Site #: WH-202

2. Location

street & number 715 W. Fourth Street
 city or town Muscatine vicinity, county Muscatine
 Legal Description: (If Rural) Township Name _____ Township No. _____ Range No. _____ Section _____ Quarter of Quarter _____
 (If Urban) Subdivision Original Town Block(s) 84 Lot(s) W 1/3 of Lots 7, 8, and 9

3. State/Federal Agency Certification [Skip this Section]

4. National Park Service Certification [Skip this Section]

5. Classification

Category of Property (Check only one box)	Number of Resources within Property		
	If Non-Eligible Property	If Eligible Property, enter number of:	
	Enter number of:	Contributing	Noncontributing
<input checked="" type="checkbox"/> building(s)	_____ buildings	<u>1</u>	_____ buildings
<input type="checkbox"/> district	_____ sites	_____	_____ sites
<input type="checkbox"/> site	_____ structures	_____	_____ structures
<input type="checkbox"/> structure	_____ objects	_____	_____ objects
<input type="checkbox"/> object	_____ Total	<u>1</u>	_____ Total

Name of related project report or multiple property study (Enter "N/A" if the property is not part of a multiple property examination).
 Title _____ Historical Architectural Data Base Number _____

A Historical and Architectural Survey of the "West Hill" neighborhood, Muscatine, Iowa 70-016

6. Function or Use

Historic Functions (Enter categories from instructions)	Current Functions (Enter categories from instructions)
<u>01A01: Domestic / Single residence</u>	<u>01B02: Domestic /Multiple Dwelling/Apartment</u>
_____	_____
_____	_____

7. Description

Architectural Classification (Enter categories from instructions)	Materials (Enter categories from instructions)
<u>09A01: House/Front-Gabled Roof</u>	foundation <u>03: Brick</u>
_____	walls <u>15B: Synthetics/Vinyl</u>
_____	roof <u>08A: Asphalt/Shingle</u>
_____	other _____

Narrative Description (SEE CONTINUATION SHEETS, WHICH MUST BE COMPLETED)

8. Statement of Significance

Applicable National Register Criteria (Mark "x" representing your opinion of eligibility after applying relevant National Register criteria)

<input checked="" type="checkbox"/> Yes <input type="checkbox"/> No <input type="checkbox"/> More Research Recommended	A	Property is associated with significant events.
<input type="checkbox"/> Yes <input checked="" type="checkbox"/> No <input type="checkbox"/> More Research Recommended	B	Property is associated with the lives of significant persons.
<input type="checkbox"/> Yes <input checked="" type="checkbox"/> No <input type="checkbox"/> More Research Recommended	C	Property has distinctive architectural characteristics.
<input type="checkbox"/> Yes <input type="checkbox"/> No <input type="checkbox"/> More Research Recommended	D	Property yields significant information in archaeology or history.

County Muscatine
City Muscatine

Address 715 W. Fourth Street

Site Number 70-01096
District Number 70-01005

Criteria Considerations

- A Owned by a religious institution or used for religious purposes.
- B Removed from its original location.
- C A birthplace or grave.
- D A cemetery.
- E A reconstructed building, object, or structure.
- F A commemorative property.
- G Less than 50 years of age or achieved significance within the past 50 years.

Areas of Significance (Enter categories from instructions)

31: Other/Neighborhood Development

Significant Dates

Construction date 1860 check if circa or estimated date
Other dates 1895 remodel

Significant Person

(Complete if National Register Criterion B is marked above)

Architect/Builder

Architect _____

Builder _____

Narrative Statement of Significance SEE CONTINUATION SHEETS, WHICH MUST BE COMPLETED

9. Major Bibliographical References

Bibliography See continuation sheet for citations of the books, articles, and other sources used in preparing this form

10. Geographic Data

UTM References (OPTIONAL)

Zone	Easting	Northing	Zone	Easting	Northing
1	_____	_____	2	_____	_____
3	_____	_____	4	_____	_____

See continuation sheet for additional UTM references or comments

11. Form Prepared By

name/title Jim Rudisill, Planning & CD Coordinator (R.L. McCarley, consultant)

organization Muscatine Historic Preservation Commission date December 5, 2005

street & number 215 Sycamore telephone 563-264-1550

city or town Muscatine state IA zip code 52761

ADDITIONAL DOCUMENTATION (Submit the following items with the completed form)

FOR ALL PROPERTIES

- Map:** showing the property's location in a town/city or township.
- Site plan:** showing position of buildings and structures on the site in relation to public road(s).
- Photographs:** representative black and white photos. If the photos are taken as part of a survey for which the Society is to be curator of the negatives or color slides, a photo/catalog sheet needs to be included with the negatives/slides and the following needs to be provided below on this particular inventory site:

Roll/slide sheet # _____	Frame/slot # _____	Date Taken _____
Roll/slide sheet # _____	Frame/slot # _____	Date Taken _____
Roll/slide sheet # _____	Frame/slot # _____	Date Taken _____

- See continuation sheet or attached **photo & slide catalog sheet** for list of photo roll or slide entries.
- Photos/illustrations without negatives are also in this site inventory file.

FOR CERTAIN KINDS OF PROPERTIES, INCLUDE THE FOLLOWING AS WELL

- Farmstead & District:** (List of structures and buildings, known or estimated year built, and contributing or non-contributing status)
- Barn:**
 - A sketch of the frame/truss configuration in the form of drawing a typical middle bent of the barn.
 - A photograph of the loft showing the frame configuration along one side.
 - A sketch floor plan of the interior space arrangements along with the barn's exterior dimensions in feet.

State Historic Preservation Office (SHPO) Use Only Below This Line

Concur with above survey opinion on National Register eligibility: Yes No More Research Recommended
 This is a locally designated property or part of a locally designated district.

Comments: _____

Evaluated by (name/title): _____ Date: _____

Iowa Site Inventory Form Continuation Sheet

Page 3

Hatch-Chaplin House
Name of Property

Muscatine
County

715 W. Fourth Street
Address

Muscatine
City

7. Narrative Description

This is a two-story, two-bay, gable-front house. The house sits on a brick foundation. The walls are frame, clad in vinyl. The gable roof is clad in asphalt shingles. The house sets on a corner lot that slopes slowly towards the rear. It appears that several additions have been constructed to the rear of the property. The house faces W. 4th Street, constructed at the rear of lots facing Broadway and Reservoir Park. The west side of the house is along Cherry Street. The house was built around 1860 by Chitterdon Hatch, with a series of rear addition shown on the 1874 birds-eye view of Muscatine. The house appears to have been remodeled with new windows and bay windows in the 1890s after Aldean Varner and her new husband Joseph B. Chaplin, who worked for Roach & Musser Sash & Door, moved into the property. The entry and surrounding windows appear to date to the original c.1860 construction.

The front (south) elevation contains a front gable with a full-width, one-story porch roof that is supported by four wood posts and two pilasters. The porch appears to have been added in the early 20th century. There are two openings under the roof. One is a single-door entry with sidelights and a seven-light transom on the far right side of the porch. The second first-story opening is located on the left side of the façade and contains a single picture window with a transom spanning the entire opening. The second-story openings of this elevation include two windows. The upper sash is a decorative "Queen Anne" multi 4-light upper sash over a single-light lower sash. Diamond panes extend across the upper portion of the upper sash. The second-story openings are aligned with the first-story openings.

The side elevations of this property are complex and exhibit a variety of elements that show what might have been a series of additions that extended the house to the rear. The right end of the west elevation contains the side wall of the house's front gable. Two openings, one on each story, are located in this front section. Each opening contains a window with the decorative four-light with diamond light sashes over a one-light sash. The remaining feature of the front section of this elevation is a dormer with a shed roof located over the first and second-story windows. The dormer has two nine-light windows that apparently open to the attic. The second section of this elevation is the projecting west end of a cross-gable rear section. The first story of the cross gable features a projecting addition that contains a series of windows. A short shed roof covers this lower extension. A series of decorative brackets run under the eave. The series of windows runs along the width of the extension and around its right side. The front windows all contain six-over-nine-light sashes. Two narrower windows are located on the extension's side. Each of these windows has four-over-six-light sashes. The second story windows of the extension include an eight-over-eight-light, double-hung window that is centered on the gable section. A similar window is located on the projected section's south side wall. There is also an eight-over-one-light, double-hung window on the extension's north side wall. Over half of the side elevation is located behind the projected cross-gable section. A series of both first and second-story openings run along the west elevation. Three nine-over-one-light, double-hung windows are located on the second story and to the left of the cross gable. The back half of this section contains a small rectangular oriel window supported by three brackets. The oriel window contains three, nine-over-one-light, double-hung windows. The first-story openings include two nine-over-one-light, double-hung windows under the second-story oriel

Iowa Site Inventory Form Continuation Sheet

Page 4

Hatch-Chaplin House
Name of Property

Muscatine
County

715 W. Fourth Street
Address

Muscatine
City

window. Three additional first-story openings are located to the right of these windows. A small nine-over-one-light, double-hung window is located to the immediate right, while a similar sized window and an entry with a non-historic, steel door are located farther to the left, near the gable extension.

The east elevation also contains a variety of openings and additions. The front section of this elevation contains only one opening, a single six-over-six-light, double-hung window on the second floor and near the back of this section. Just behind this window a wide chimney extends out from the wall. A narrow two-over-two-light, first-story window is located in front of the chimney. A pair of windows on both the first and second stories is located behind the chimney. The east elevation of the back section of the house is especially decorative with a variety of openings and other features. The second-story openings contain a pair of narrow, one-over-one-light, double-hung windows centered on the rear section. A pair of larger, one-over-one-light, double-hung windows is located on each side of the centered windows. An attic dormer is located over the smaller, centered windows. A shed roof covers the dormer. The dormer contains three, nine-light, fixed-sash windows. The first story of this back section is contained within a shed-type extension that was flush with the east wall of the front section of the house. Three sets of windows run along the wall. The first set includes nine-over-one-light, double-hung windows. The middle set of windows and the last set contain nine-over-one-light, double-hung sashes. An entry is located between the second and third sets of windows.

The rear elevation contains the rear gable. A chimney is centered up through the gable and extends out slightly from the wall. A one-over-one-light, double-hung window is located on each side of the chimney on both the first and second story. The only other opening on the rear elevation contains a pair of first-story windows on the side of the shed-type extension located on the east elevation.

8. Narrative Statement of Significance

The Hatch-Chaplin House does not appear to be individually eligible for the National Register of Historic Places under Criteria A, B, or C. However, it does appear to be a contributing building in a potential "West Hill" neighborhood historic district.

Chitterdon U. Hatch, a carpenter, built this house around 1860, most likely for his family after he moved to Muscatine in 1856. He is one of 15 carpenters and builders recorded in the 1859 directory. He does not appear to have been a significant figure in the history of the community. The house does retain its general footprint and basic integrity, but there have been modifications that appear to date to the 1890s or earlier. Joseph B. and Aldean Chaplin likely replaced windows throughout the house in the 1890s, as Joseph worked for Roach & Musser Sash & Door. Other modifications may have been made at this time. It does not exhibit any specific style, and its front-gable roof construction form is common in the neighborhood and throughout the city. The later vinyl siding obscures any other decorative features that may have been added. In addition, no significant historical event is known to have occurred on the property. Thus, the Chitterdon Hatch House does not appear to be individually eligible for the National Register of Historic Places under Criteria A, B, or C.

Iowa Site Inventory Form Continuation Sheet

Page 5

Hatch-Chaplin House
Name of Property

Muscatine
County

715 W. Fourth Street
Address

Muscatine
City

However, the Chitterdon Hatch House does appear to be a contributing building in a potential "West Hill" neighborhood historic district. Hatch and his wife Maria had only been in Muscatine about three years when they purchased this property. As a newly arrived resident to the community, Hatch likely did not influence others to construct homes in this area, but he did help to maintain the neighborhood stability and growth through his decision. It also appears possible a small house might have already been located on the property and he razed it and built a more substantial building, or he improved the existing house. In either case, the improvements he made substantially improved the property and created a stronger attraction to other potential homeowners. This greatly benefited the neighborhood development. Likewise, the Chaplins continued to improve the house with new windows in the 1890s. This house contributes to this potential historic district's history and architecture.

Joseph Green sold Lots 7, 8 & 9, Block 84 and the W 1/2 of Lots 7 & 8, Block 49 to George B. Stone on December 17, 1855 for \$1500 (Book Q, Page 134). This price likely indicates some construction on both sets of lots. The 1874 birds-eye view shows a house on the west half of Lots 7 & 8 in Block 49 (313 Cherry Street) and a house on the west 1/3 of Lots 7, 8 & 9 in Block 84 (715 W. Fourth Street). Chitterdon Hatch bought west 1/3 of Lots 7, 8 & 9 of Block 84 from George Stone on May 1, 1859 for \$700 (Book 5, Page 215). The actual purchase record for the W 1/3 of Lots 7, 8 & 9 of Block 84 could not be found. However, the May 1, 1859 date is established by a bond transaction between Hatch and Stone. This bond appears to be a contract purchase of the property. If a small house was located on the lot, it appears to have been demolished by Hatch, or substantially enlarged. Chitterdon Hatch was born in Massachusetts in 1823. After learning the carpenter's trade in his native state, he joined the gold rush to California in 1849. After five years in the gold fields he returned to New England, married and eventually moved to Muscatine. He is not listed in the 1856 city directory, but is one of 15 carpenters and builders recorded in the 1859 directory. The 1859 city directory identifies Hatch as living at the "nec of Cherry and Fourth", which would correspond to this location. In addition, both Hatch and Marie are also recorded in the 1860 census as living in the neighborhood of Henry O'Connor and W.R. Stone. The 1859 directory lists O'Connor at "scc (assumed to be sec) 4th & Cherry"; while Stone's location is recorded as "es Cherry b. 3rd & 4th." Others neighbors listed in the census include Michael Fay (Fahey), Cyrus Hawley, George B. Stone and Joseph Green. Hatch died in Muscatine in 1893.

Hatch sold the W 1/3 of Lots 7, 8 & 9, Block 84 on March 12, 1866 to Caroline Klein for \$4000 (Book 1, Page 623). The large increase in price indicates Hatch made a substantial improvement to the property during his ownership. Edward Klein, who is assumed to be the husband of Caroline, was listed in the 1866 directory as the resident at "Fourth ne cor Cherry." No occupation was listed for him in the 1866 directory. E. Klein was listed in the 1869-70 directory. He was identified as the mayor of Muscatine. The 1870 census lists E. Klein (66, male, justice of peace) with C.C. Klein (female, 60) who had \$4000 in real estate. There was no Caroline, Edward or other Klein listed in the 1874-75 or 1876-77 directories at this address. However, Eugene Klein was listed in the 1876-77 directory at "92 W. Fourth," which is likely this location (90 W. Fourth was associated with the Fahay family, who lived at 711 W. Fourth, now 3 Cherry Lane). Eugene was identified as a clerk at J.G. Gordon's. It is not known what relationship Eugene was to Edward and Catherine. No occupation was listed for Eugene in the 1876-77 directory, but in the 1877-

Iowa Site Inventory Form Continuation Sheet

Page 6

Hatch-Chaplin House	Muscatine
Name of Property	County
715 W. Fourth Street	Muscatine
Address	City

78 directory he is identified as the manager of the J.G. Gordon estate. His residence is listed as "Cherry ne corn 4th." The 1879 directory did not list any Klein. Mrs. C. Klein, widow, was listed in the 1883-86 directory as the resident. The 1874 birds-eye view of Muscatine shows the gable-front, two-story house with a full front porch and a series of rear additions.

The directory was apparently completed early in 1883, because Caroline Klein, widow, sold the west 1/3 of Lots 7, 8 & 9, Block 84 on August 11, 1883 to Caroline Varner for \$2000 (Book 18; page 87). Varner purchased the property for two daughters, Cad and Aldean Varner, to use as their residence. Both sisters are listed in the 1886-87 and 1889-92 directories as the residents. Aldean Varner married Joseph Chaplin on September 4, 1890. They were listed as the residents from the 1891-92 directory through the 1923-24 directory. Chaplin started his career with the Brent Manufacturing Company, later the Muscatine Sash and Door Company, in 1888. For the first several years he worked as the company's bookkeeper. By 1895 he was a salesman for the company. He was identified as a traveling agent for the company in the 1900 city directory. The 1904 and 1907 directories both listed him as a secretary for the Roach and Musser Company. It was likely during this later period that the house was partially remodeled, with new window sashes, bay windows, and dormer. The 1910 census confirms them at 715 W. Fourth. It identifies Joseph B., age 48, as the secretary of a sash and door company, as well as his wife Aldeen, age 46, who had no children. Cad Cook, a recent widow, age 50, lived at the adjacent 408 Broadway. She appears to have shortly moved back in with her sister, renting her house. Cad (Varner) Cook, widow of Ed, is formally listed as a resident in the 1919 city directory. Joseph and Aldean Chaplin and Cad Varner Cook are all listed in the 1920 census at 715 W. Fourth. Joseph Chaplin, who was born in Muscatine in 1862, died in 1924. He was an active business leader of the community, spending nearly his entire professional life with the Roach & Musser Sash and Door Company. He was serving as vice president and general manager of the company, a position he had held since 1916, when he died. The company developed into a major economic force in the community during his tenure. That development helped to maintain the community's association with the lumber industry and provided an economic base for future business development in the community.

After Chaplin died in 1924, his widow continued to live in the house until she died in October 1947, according to city directories. It is assumed her sister Cad Varner Cook continued to live with her until she died in August 1934. According to Cad Cook's obituary, she was an active member of the First Congregational Church; had served on the boards of the Old Ladies Home association and the Day Nursery; and had also been a charter member of the Geneva Golf and Country Club. The obituary for Aldean Chaplin did not list any of her activities.

The heirs sold the property on February 6, 1948 to Lloyd A. Foster (Book 123, Page 515). Foster apparently rented rooms or apartments to others. Beginning with the 1949 directory, it appears four separate residents were listed, indicating the house was converted into apartments around that time. Lloyd and Isabel Foster were listed in both the 1949 and 1952 directories. He was a supervisor for Muscatine Bank and Trust. Nathan and Marie Hursh were listed in the 1949 directory. He was an optometrist. Harold and Jean Kent also were residents at the house, according to the 1949 directory. He was an assistant manager at GPC. The last residents listed in the directory were Ladd and Carol

Iowa Site Inventory Form Continuation Sheet

Page 7

Hatch-Chaplin House
Name of Property

Muscatine
County

715 W. Fourth Street
Address

Muscatine
City

Steinmetz. Steinmetz was an accountant with Mississippi Valley F&G. The 1952 directory listed fewer residents. In addition to Foster, Clyde and Emma Randelman were listed as residents. No occupation was listed for Randelman.

Stanley Howe purchased the property on March 24, 1953 (Book 143, Page 341). Howe would eventually be named the vice president for production at Homo-o-Nize (currently HNI Corporation). He and his wife Helen would continue to be listed as residents through the 1958 directory. During this time he continued to work at HON. The 1954 directory identified him as the production division manager, while the 1959 directory listed him as the vice president for production. Others listed in the 1954 directory were Melvin and Margaret Freeze; Duane and Patricia Gilleland; and Leota Cole. Freeze worked as a draftsman for Stanleys and Gilleland was an employee for Roach and Musser. No occupation was listed for Cole. In addition to Howe, the 1956 directory listed Clarinda Reid, Lucia Fordyce and Fritz and Marlene Thoerna as residents. No occupation was listed for Reid. Fordyce was a dietician at General Hospital and Thoerna was an engineer at Stanleys. The 1958 listing of residents included Howe, Fordyce, Bill and Charlene James and Mrs. Hazel Harrington. James was a student and no occupation was listed for Harrington. Stanley and Helen Howe continued to own the property until 1968.

9. Major Bibliographical References

"Biographies For Muscatine County Iowa 1879 (J.W. Varner)," *History of Muscatine County, Iowa, Biographical Section*. Chicago: Western Historical Company, 1879, page 621.

Census Records, United States Census Bureau, 1860, 1910, 1920.

City Directories, Muscatine. Various publishers, 1856-1959. Available as the Musser Public Library.

"Death of Edward Klein," Obituary, *Muscatine Journal*, July 13, 1876, Page 6

"Death of Mrs. Catherine Klein," Obituary, *Muscatine Journal*, February 5, 1896, Page 4

Deed/Abstract Records, Recorder's Office, Muscatine County Courthouse, Muscatine, Iowa.

"J.B. Chaplin ...Taken By Death," news story and obituary, *Muscatine Journal*, November 20, 1924, Page 1

"Mrs. Chaplin, 83, Dies Suddenly At Home Here," Obituary, *Muscatine Journal*, October 27, 1947, page 5

Sanborn Map Company. "Muscatine, Iowa," Sanborn fire insurance maps. Pelham, NY: Sanborn Map Company, 1883, 1888, 1892, 1899, 1907, 1912, 1919, 1928. Accessed online at: Sanborn.umi.com.

Iowa Department of Cultural Affairs
 State Historical Society of Iowa
Iowa Site Inventory Form
Continuation Sheet

Site Number 70-01096
 Related District Number 70-01005

Page 8

Hatch-Chaplin House
 Name of Property

Muscatine
 County

715 W. Fourth Street
 Address

Muscatine
 City

Location Map



Plans of buildings on site (from assessor's office)

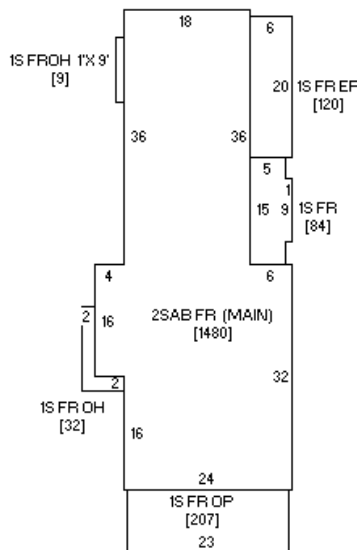

(front – Street)

Iowa Site Inventory Form Continuation Sheet

Site Number 70-01096

Related District Number 70-01005

Page 9

Hatch-Chaplin House
Name of Property

Muscatine
County

715 W. Fourth Street
Address

Muscatine
City

Photograph of building (digital image)

